

TC74LVX273F, TC74LVX273FW, TC74LVX273FT

Octal D-Type Flip-Flop with Clear

The TC74LVX273F/ FW/ FT is a high-speed CMOS octal D-flip flop fabricated with silicon gate CMOS technology. Designed for use in 3-V systems, it achieves high-speed operation while maintaining the CMOS low power dissipation.

This device is suitable for low-voltage and battery operated systems.

Information signals applied to D inputs are transferred to the Q outputs on the positive going edge of the clock pulse. When the CLR input is held low, the Q outputs are in the low logic level independent of the other inputs.

An input protection circuit ensures that 0 to 5.5V can be applied to the input pins without regard to the supply voltage. This device can be used to interface 5V to 3V systems and two supply systems such as battery back up. This circuit prevents device destruction due to mismatched supply and input voltages.

Features

- High-speed: $f_{max} = 150 \text{ MHz (typ.) (} V_{CC} = 3 \text{ V)}$
- Low power dissipation: $I_{CC} = 4 \mu\text{A (max) (} T_a = 25^\circ\text{C)}$
- Input voltage level: $V_{IL} = 0.8 \text{ V (max) (} V_{CC} = 3 \text{ V)}$
 $V_{IH} = 2.0 \text{ V (min) (} V_{CC} = 3 \text{ V)}$
- Power-down protection provided on all inputs
- Balanced propagation delays: $t_{pLH} \approx t_{pHL}$
- Low noise: $V_{OLP} = 0.8 \text{ V (max)}$
- Pin and function compatible with 74HC273

Note: xxxFW (JEDEC SOP) is not available in Japan.

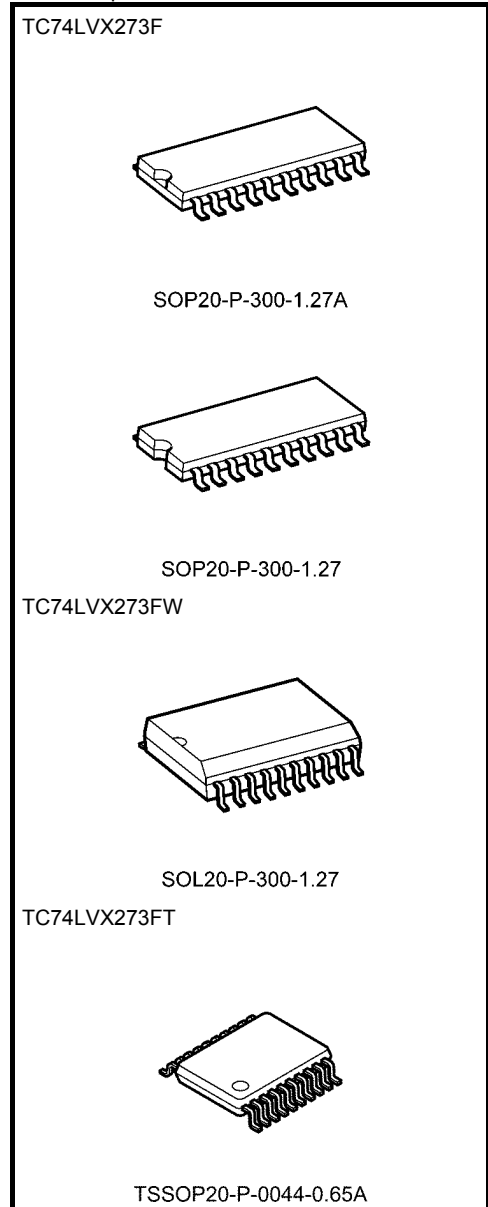

Weight	
SOP20-P-300-1.27A	: 0.22 g (typ.)
SOP20-P-300-1.27	: 0.22 g (typ.)
SOL20-P-300-1.27	: 0.46 g (typ.)
TSSOP20-P-0044-0.65A	: 0.08 g (typ.)

Pin Assignment (top view)

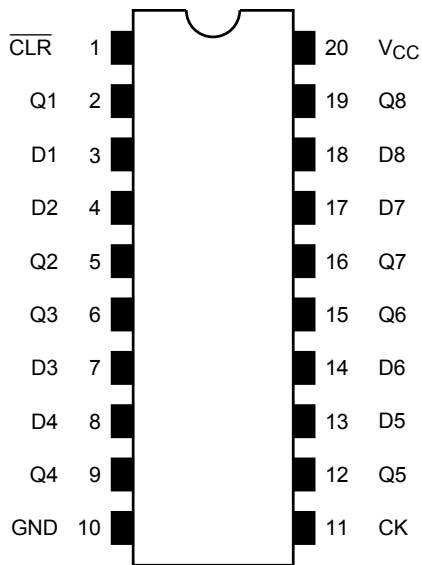

IEC Logic Symbol

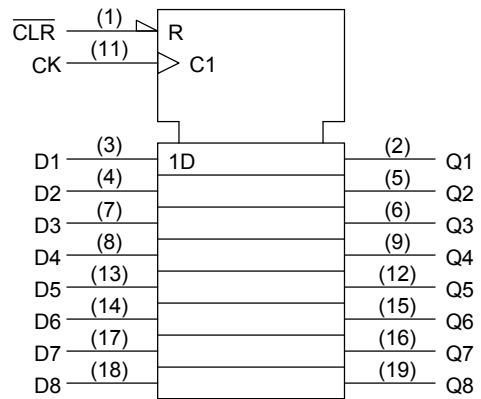

Truth Table

Inputs			Outputs	Function
$\overline{\text{CLR}}$	D	CK	Q	
L	X	X	L	Clear
H	L	\uparrow	L	—
H	H	\uparrow	H	—
H	X	\downarrow	Q _n	No change

X: Don't care

System Diagram

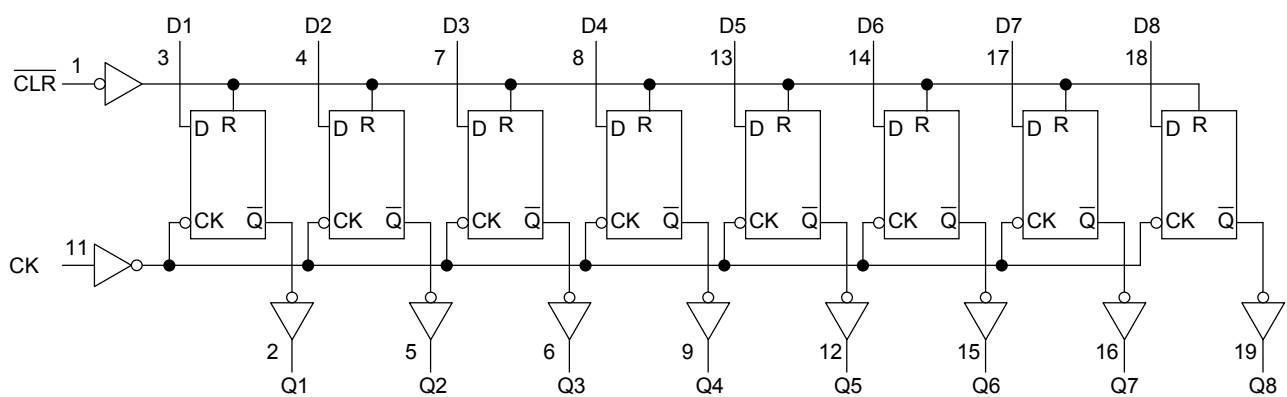

Absolute Maximum Ratings (Note)

Characteristics	Symbol	Rating	Unit
Supply voltage range	V_{CC}	-0.5 to 7.0	V
DC input voltage	V_{IN}	-0.5 to 7.0	V
DC output voltage	V_{OUT}	-0.5 to $V_{CC} + 0.5$	V
Input diode current	I_{IK}	-20	mA
Output diode current	I_{OK}	± 20	mA
DC output current	I_{OUT}	± 25	mA
DC V_{CC} /ground current	I_{CC}	± 75	mA
Power dissipation	P_D	180	mW
Storage temperature	T_{stg}	-65 to 150	$^{\circ}C$

Note: Exceeding any of the absolute maximum ratings, even briefly, lead to deterioration in IC performance or even destruction.

Recommended Operating Conditions (Note)

Characteristics	Symbol	Rating	Unit
Supply voltage	V_{CC}	2.0 to 3.6	V
Input voltage	V_{IN}	0 to 5.5	V
Output voltage	V_{OUT}	0 to V_{CC}	V
Operating temperature	T_{opr}	-40 to 85	$^{\circ}C$
Input rise and fall time	dt/dv	0 to 100	ns/V

Note: The recommended operating conditions are required to ensure the normal operation of the device. Unused inputs must be tied to either VCC or GND.

Electrical Characteristics

DC Characteristics

Characteristics		Symbol	Test Condition	Ta = 25°C			Ta = -40 to 85°C		Unit		
				V _{CC} (V)	Min	Typ.	Max	Min		Max	
Input voltage	H-level	V _{IH}	—	2.0	1.5	—	—	1.5	—	V	
				3.0	2.0	—	—	2.0	—		
				3.6	2.4	—	—	2.4	—		
	L-level	V _{IL}	—	2.0	—	—	0.5	—	0.5		
				3.0	—	—	0.8	—	0.8		
				3.6	—	—	0.8	—	0.8		
Output voltage	H-level	V _{OH}	V _{IN} = V _{IH} or V _{IL}	I _{OH} = -50 μA	2.0	1.9	2.0	—	1.9	—	V
				I _{OH} = -50 μA	3.0	2.9	3.0	—	2.9	—	
				I _{OH} = -4 mA	3.0	2.58	—	—	2.48	—	
	L-level	V _{OL}	V _{IN} = V _{IH} or V _{IL}	I _{OL} = 50 μA	2.0	—	0	0.1	—	0.1	
				I _{OL} = 50 μA	3.0	—	0	0.1	—	0.1	
				I _{OL} = 4 mA	3.0	—	—	0.36	—	0.44	
Input leakage current		I _{IN}	V _{IN} = 5.5 V or GND	3.6	—	—	±0.1	—	±1.0	μA	
Quiescent supply current		I _{CC}	V _{IN} = V _{CC} or GND	3.6	—	—	4.0	—	40.0	μA	

Timing Requirements (input: t_r = t_f = 3 ns)

Characteristics	Symbol	Test Condition	Ta = 25°C		Ta = -40 to 85°C		Unit
			V _{CC} (V)	Limit	Limit	Limit	
Minimum pulse width (CK)	t _{W(L)} t _{W(H)}	—	2.7	8.0	9.5	ns	
			3.3 ± 0.3	5.5	6.5		
Minimum pulse width ($\overline{\text{CLR}}$)	t _{W(L)}	—	2.7	7.5	8.5	ns	
			3.3 ± 0.3	5.0	6.0		
Minimum set-up time	t _s	—	2.7	8.0	9.5	ns	
			3.3 ± 0.3	5.5	6.5		
Minimum hold time	t _h	—	2.7	1.0	1.0	ns	
			3.3 ± 0.3	1.0	1.0		
Minimum removal time ($\overline{\text{CLR}}$)	t _{rem}	—	2.7	4.0	4.0	ns	
			3.3 ± 0.3	2.5	2.5		

AC Characteristics (input: $t_r = t_f = 3 \text{ ns}$)

Characteristics	Symbol	Test Condition			Ta = 25°C			Ta = -40 to 85°C		Unit
			V _{CC} (V)	C _L (pF)	Min	Typ.	Max	Min	Max	
Propagation delay time (CK-Q)	t _{pLH}	—	2.7	15	—	9.0	16.9	1.0	20.5	ns
				50	—	11.5	20.4	1.0	24.0	
	3.3 ± 0.3		15	—	7.1	11.0	1.0	13.0		
			50	—	9.6	14.5	1.0	16.5		
Propagation delay time ($\overline{\text{CLR}}$ -Q)	t _{pHL}	—	2.7	15	—	9.3	17.6	1.0	20.5	ns
				50	—	11.8	21.1	1.0	24.0	
			3.3 ± 0.3	15	—	7.3	11.5	1.0	13.5	
				50	—	9.8	15.0	1.0	17.0	
Maximum clock frequency	f _{max}	—	2.7	15	55	110	—	45	—	MHz
				50	45	60	—	40	—	
			3.3 ± 0.3	15	95	150	—	80	—	
				50	60	90	—	50	—	
Output to output skew	t _{osLH}	(Note 1)	2.7	50	—	—	1.5	—	1.5	ns
	t _{osHL}			3.3 ± 0.3	50	—	—	1.5	—	
Input capacitance	C _{IN}	(Note 2)		—	4	10	—	10	pF	
Power dissipation capacitance	C _{PD}	(Note 3)		—	31	—	—	—	pF	

Note 1: Parameter guaranteed by design.

$$(t_{osLH} = |t_{pLHm} - t_{pLHn}|, t_{osHL} = |t_{pHLm} - t_{pHLn}|)$$

Note 2: Parameter guaranteed by design.

Note 3: C_{PD} is defined as the value of the internal equivalent capacitance which is calculated from the operating current consumption.

Average operating current can be obtained by the equation:

$$I_{CC(opr)} = C_{PD} \cdot V_{CC} \cdot f_{IN} + I_{CC}/8 \text{ (per F/F)}$$

And the total C_{PD} when n pcs. of F/F operate can be gained by the following equation:

$$C_{PD} \text{ (total)} = 22 + 9 \cdot n$$

Noise Characteristics (Ta = 25°C, input: tr = tf = 3 ns, CL = 50 pF)

Characteristics	Symbol	Test Condition	VCC (V)	Typ.	Limit	Unit
Quiet output maximum dynamic VOL	VOLP	—	3.3	0.5	0.8	V
Quiet output minimum dynamic VOL	VOLV	—	3.3	-0.5	-0.8	V
Minimum high level dynamic input voltage VIH	VIHD	—	3.3	—	2.0	V
Maximum low level dynamic input voltage VIL	VILD	—	3.3	—	0.8	V

Input Equivalent Circuit

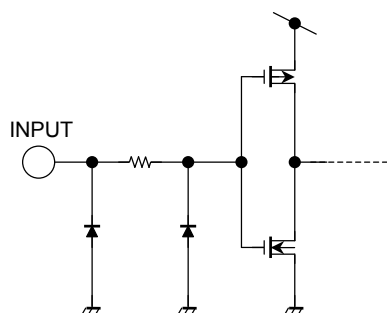

Package Dimensions

SOP20-P-300-1.27A

Unit: mm

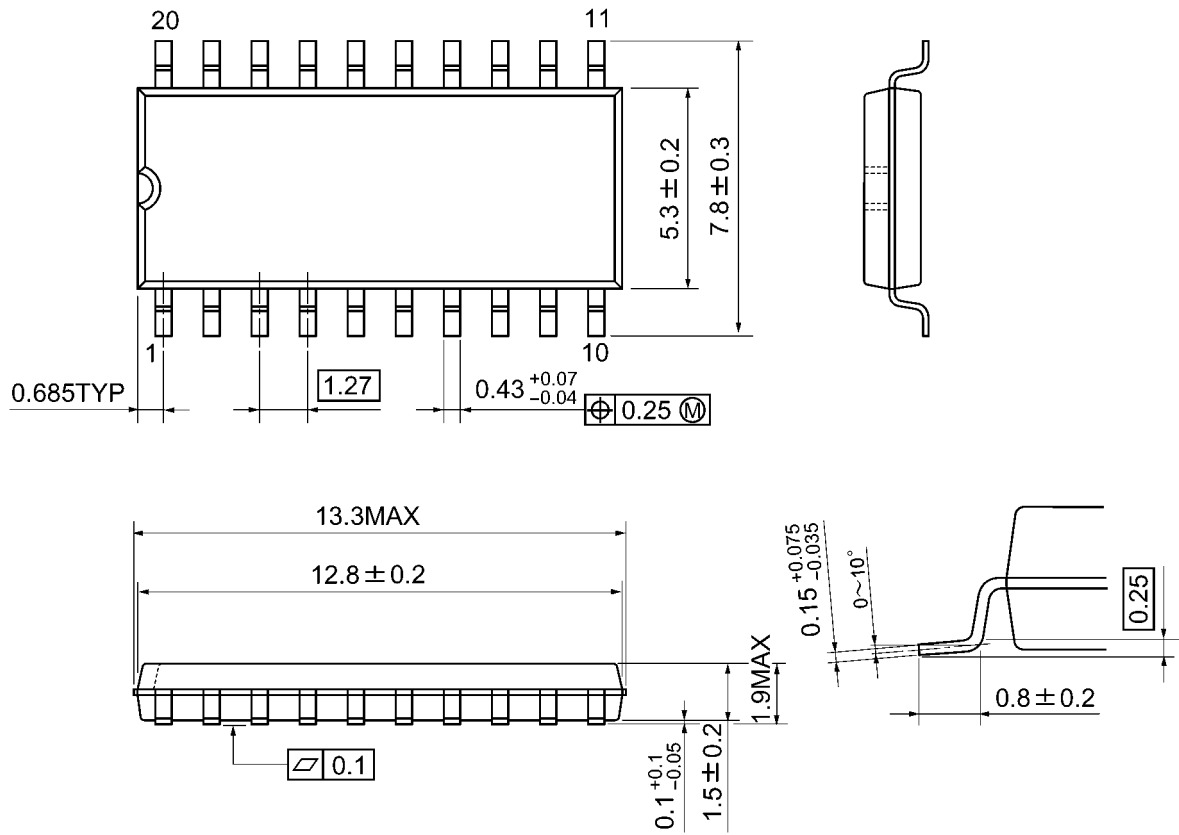

Weight: 0.22 g (typ.)

Package Dimensions

SOP20-P-300-1.27

Unit : mm

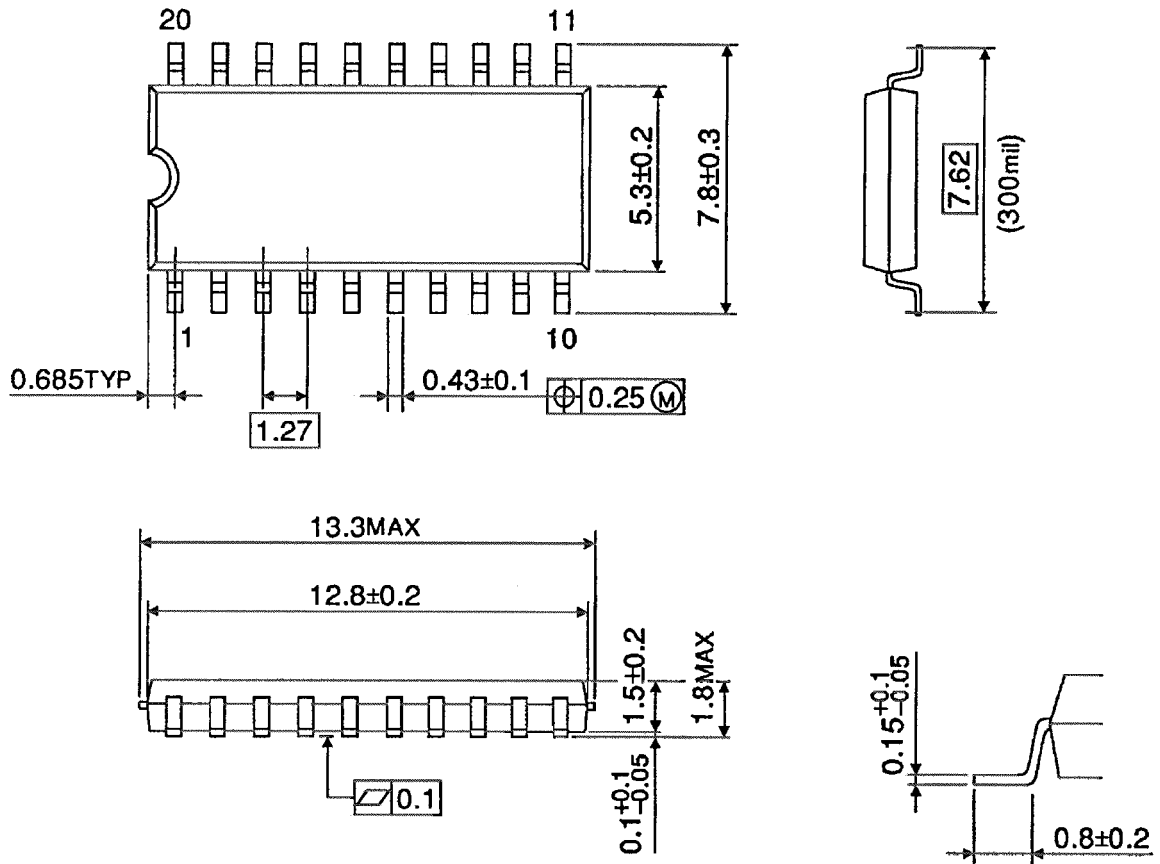

Weight: 0.22 g (typ.)

Package Dimensions (Note)

SOL20-P-300-1.27

Unit : mm

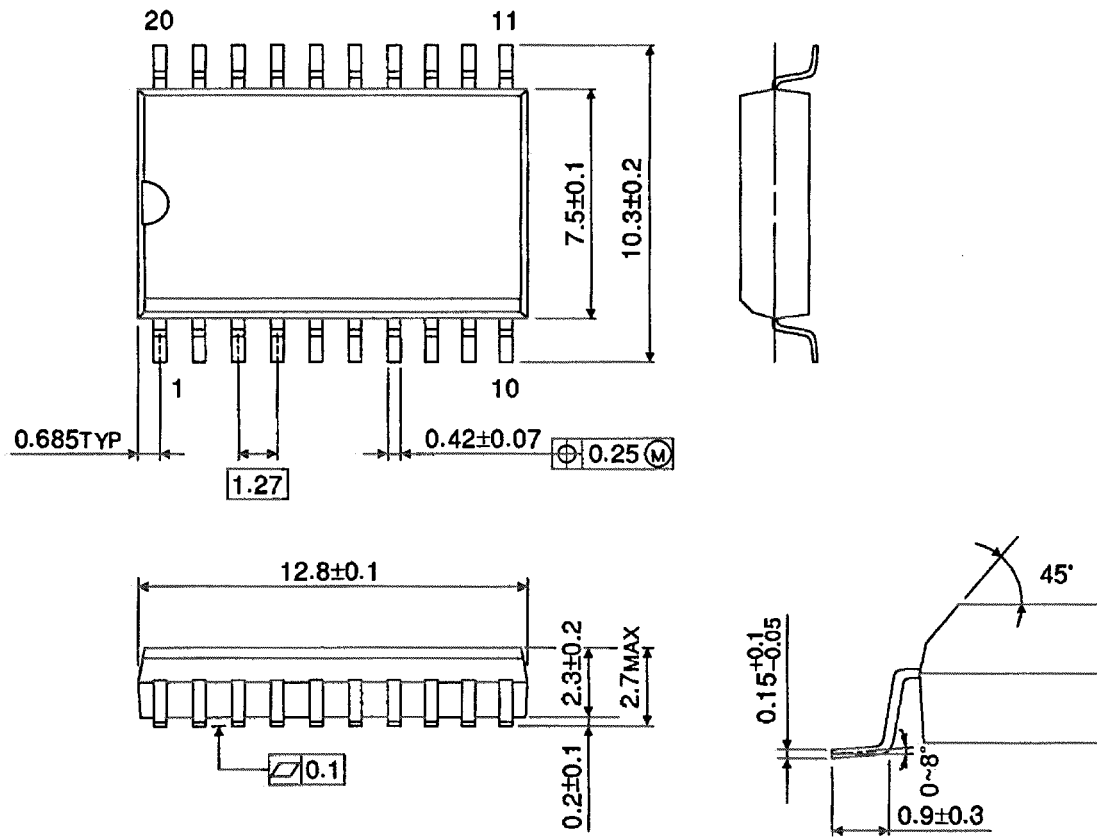

Note: This package is not available in Japan.

Weight: 0.46 g (typ.)

Package Dimensions

TSSOP20-P-0044-0.65A

Unit: mm

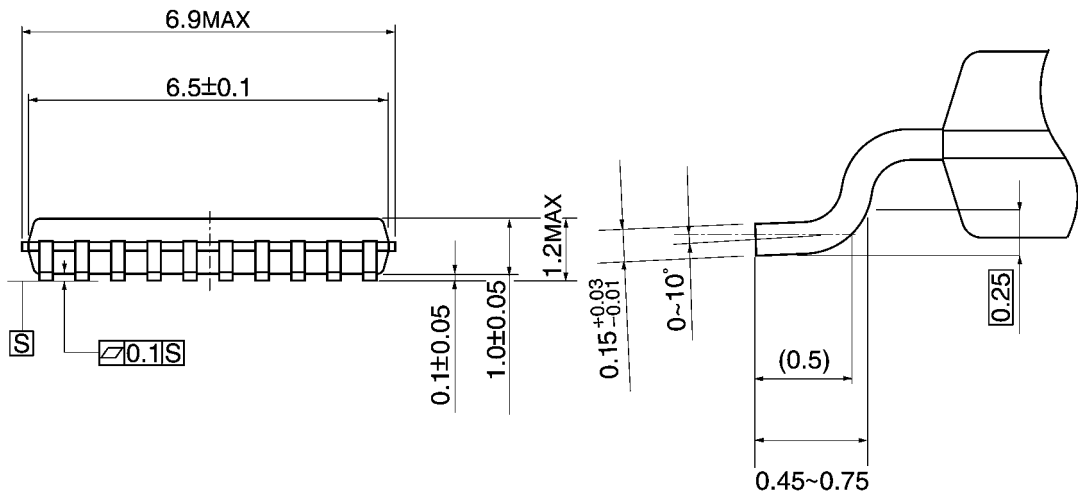
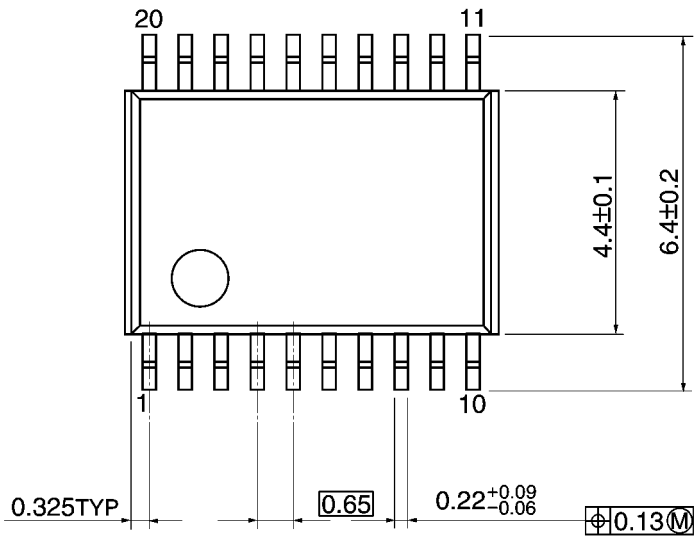

Weight: 0.08 g (typ.)

Note: Lead (Pb)-Free Packages**SOP20-P-300-1.27A TSSOP20-P-0044-0.65A****RESTRICTIONS ON PRODUCT USE**

20070701-EN

- The information contained herein is subject to change without notice.
- TOSHIBA is continually working to improve the quality and reliability of its products. Nevertheless, semiconductor devices in general can malfunction or fail due to their inherent electrical sensitivity and vulnerability to physical stress. It is the responsibility of the buyer, when utilizing TOSHIBA products, to comply with the standards of safety in making a safe design for the entire system, and to avoid situations in which a malfunction or failure of such TOSHIBA products could cause loss of human life, bodily injury or damage to property.
In developing your designs, please ensure that TOSHIBA products are used within specified operating ranges as set forth in the most recent TOSHIBA products specifications. Also, please keep in mind the precautions and conditions set forth in the "Handling Guide for Semiconductor Devices," or "TOSHIBA Semiconductor Reliability Handbook" etc.
- The TOSHIBA products listed in this document are intended for usage in general electronics applications (computer, personal equipment, office equipment, measuring equipment, industrial robotics, domestic appliances, etc.). These TOSHIBA products are neither intended nor warranted for usage in equipment that requires extraordinarily high quality and/or reliability or a malfunction or failure of which may cause loss of human life or bodily injury ("Unintended Usage"). Unintended Usage include atomic energy control instruments, airplane or spaceship instruments, transportation instruments, traffic signal instruments, combustion control instruments, medical instruments, all types of safety devices, etc.. Unintended Usage of TOSHIBA products listed in this document shall be made at the customer's own risk.
- The products described in this document shall not be used or embedded to any downstream products of which manufacture, use and/or sale are prohibited under any applicable laws and regulations.
- The information contained herein is presented only as a guide for the applications of our products. No responsibility is assumed by TOSHIBA for any infringements of patents or other rights of the third parties which may result from its use. No license is granted by implication or otherwise under any patents or other rights of TOSHIBA or the third parties.
- Please contact your sales representative for product-by-product details in this document regarding RoHS compatibility. Please use these products in this document in compliance with all applicable laws and regulations that regulate the inclusion or use of controlled substances. Toshiba assumes no liability for damage or losses occurring as a result of noncompliance with applicable laws and regulations.